

Separate catalog available

## MC Series conveyor



### Versatile Conveyors for Flat or Inclined Use

Conveyor height can be adjusted easily without using tools. (MC-20 to MC-40 only)

### Easy Installation of Additional Options

Various optional equipment can be easily attached to the conveyor or frame.

### Lightweight Design

Strong yet lightweight extruded aluminum construction allows the conveyor to be repositioned easily.

### Model Name Key

**MC-20-3**

Belt width 3=300, 4=400, 5=500, 6=600, 7=700, 10=1000 (mm)  
 Frame length 20=2000, 30=3000, 40=4000, 50=5000, 60=6000 (mm)

### Lineup

Lineup	Frame length (mm)	Belt width (mm)	300	400	500	600	700	1000
MC-20	2000		○	○	○			
MC-30	3000		○	○	○			
MC-40	4000		○	○	○			
MC-50	5000				○	○	○	○
MC-60	6000				○	○	○	

### Standard Specifications

Power supply	100 VAC
Power consumption	Single phase, 100 VAC 1 A
Transport speed 50 Hz	5.4 m/min.
60 Hz	6.5 m/min.
Payload	25kg
Height (from floor to belt surface)	1000 to 1600 mm in 50 mm increments (MC-50 and larger models are 1000 to 1500 mm with 50 mm increments)
Frame length	2000, 3000, 4000, 5000, 6000 (mm)
Belt width	300, 400, 500, 600, 700, 1000 (mm)
Frame width	Belt width + 80 mm
Full width	Belt width + 142 mm

### Options

Special leg (special height)	Semi-standard	200 VAC	
Stacked pallets counter		Rough-surface belt	Semi-standard
Variable speed motor	Semi-standard	Take-out robot descent inhibit sensor	Semi-standard
Heat-resisting belt	Semi-standard	Fast forward switch	
Side guide	Semi-standard	Knife edge	Semi-standard
Upper-surface guide	Semi-standard	Emergency stop switch	
Belt with crosspieces	Semi-standard	Weight resisting leg	Semi-standard
Reject circuit	Semi-standard	Level adjustment pad*1	
Overload warning device	Semi-standard	Caster*2	
Anti-electrostatic device	Semi-standard	Harness extension for linking with take-out robot*3	

Semi-standard : Please note that semi-standard options require additional time for manufacturing.  
 \*1 Available as standard for the MC-50 and larger models  
 \*2 Optionally available for the MC-50 and larger models  
 \*3 Harness extends standard 8 m connection to 16 m.

### Dimensional Drawing (mm)

#### MC-20/30/40

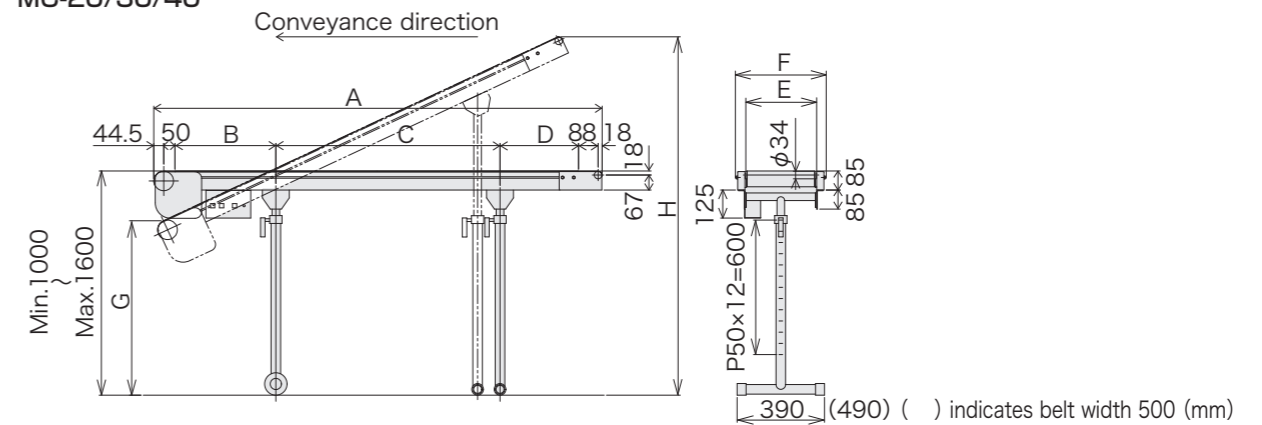

Model	A	B	C	D	E	F	G	H
MC-20-3					300	442		
-4	2000	450	1000	350	400	542	790	1565
-5					500	642		
MC-30-3					300	442		
-4	3000	600	1400	800	400	542	735	1889
-5					500	642		
MC-40-3					300	442		
-4	4000	600	2400	800	400	542	834	1818
-5					500	642		

#### MC-50/60

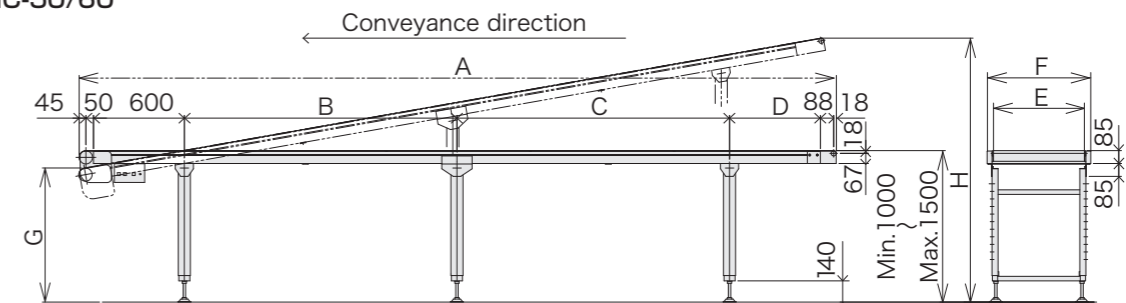

Model	A	B	C	D	E	F	G	H
MC-50-5					500	642		
-6	5000	1800	1800	600	600	742	909	1596
-7					700	842		
-10					1000	1142		
MC-60-5					500	642		
-6	6000	2300	2300	600	600	742	929	1576
-7					700	842		