

1 All-Axis Servo Driven Type Take-Out Robot

LA-1318S/D, LA-1825S

LA-1318S/D, LA-1825S

For reliable take-out of very large molded products such as automobile parts and housing materials

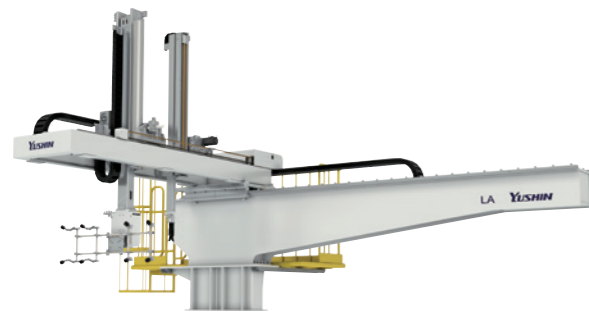

Clamping force 1300 - 2500 tf

LOW Low posture (Double speed mechanism)

All-axis servo-driven

SMART*1 structure

Swift, powerful action is achieved with lightweight, high-rigidity frames used for the axes. Light products are quickly taken out, and heavier products are handled with enhanced stability. Take-out time is 19% faster than with conventional models.

*1 Abbreviation for "Saving Material with Analysis-based Reinforcement Technology"

Standard Specifications

Power supply	Drive method	Controller model	Working air pressure	Flip angle
200/220 VAC (50/60 Hz) 3 phase	Digital servo motor 3/5-axis	E-touch II / E-touch compact-YC	0.49MPa	90°

Model	Power consumption	Traverse stroke [mm]	Kick stroke [mm]		Vertical stroke [mm]		Air consumption [NL/cycle]	Payload [kg]	Target IMM clamp capacity [tf]
			Main arm	Sub arm	Main arm	Sub arm			
LA-1318S	2.7 kVA 200 VAC EC : A 8.5 E2 : A 7.6	3500 (4500)	1925	—	2100 (2500)	—	91	35 (50)	1300-1800
LA-1318D	2.6 kVA 200 VAC EC : A 11.7 E2 : A 10.4		1755	1755			2100 (2500)		
LA-1825S	2.7 kVA 200 VAC EC : A 8.5 E2 : A 7.6	3500 (4500) (5000)	1925 (1800)	—	2500 (3200)	—	130 (101)	50 (65)	1800-2500

() : Modified stroke () : Increased maximum payload
S type : Robot is equipped with main arm only. D type : Robot is equipped with main arm and sub arm.
Payload includes the end-of-arm tool.

■ Rear (Non-operator) Side Discharge Direction (mm)

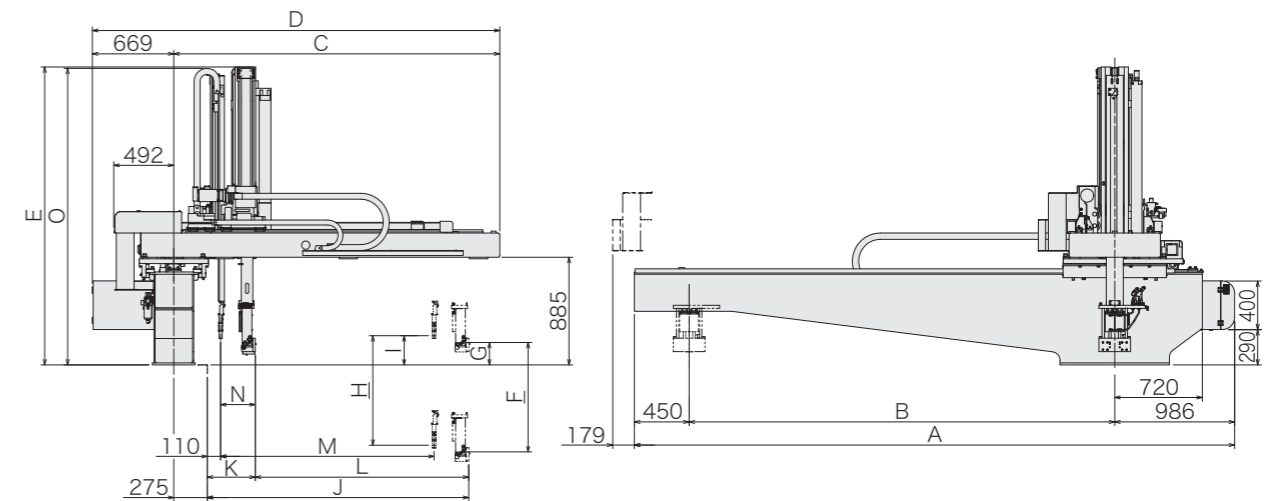

■ Operator Side Discharge Direction (mm)

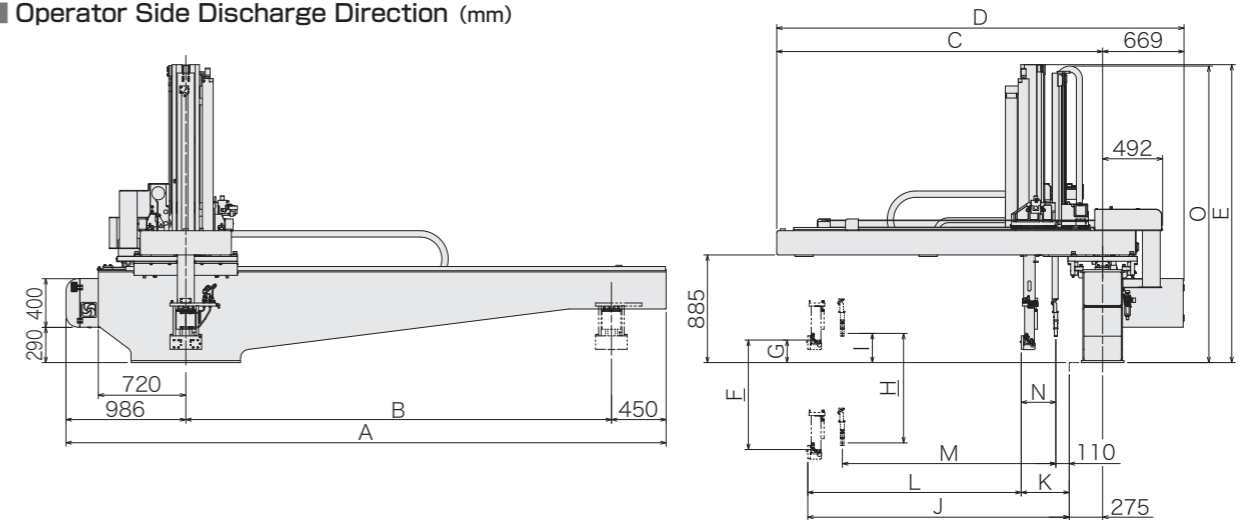

[mm]

Model	A	B	C	D	E	F	G	H	I	J	K	L	M	N	O
LA-1318S	4936 (5936)	3500 (4500)			2450 (2650)	2100 (2500)		—	—		225	1925	—	—	—
LA-1318D			2680	3343			185	2100 (2500)	240	2150	395	1755	1755	285	2439 (2639)
LA-1825S	4936 (5936) (6436)	3500 (4500) (5000)			2650 (3000)	2500 (3200)		—	—		225 *350	1925 *1800	—	—	—

() : Modified stroke *When modified vertical stroke 3,200 mm specifications are selected

LA-1318S/D, LA-1825S

All-Axis Servo Driven Type Take-Out Robot