

MC Series Conveyor

Belt Conveyors for Flat or Inclined Applications

Features



Versatile conveyors for flat or inclined use

Conveyor height can be adjusted easily.
(The height of small MC-20 to MC-40 models can be adjusted without hand tools.)

Install full range of options with ease

Various options are easy to install on the conveyor.

Lightweight design

Strong yet lightweight extruded aluminum construction allows conveyor to be repositioned easily.



Model Nomenclature

MC-20-3

Belt width 3 = 300, 4 = 400, 5 = 500, 6 = 600, 7 = 700 (mm)
Frame length 20 = 2000, 30 = 3000, 40 = 4000, 50 = 5000, 60 = 6000 (mm)

Lineup

Lineup	Belt width (mm) Frame length (mm)	300	400	500	600	700	1000
MC-20	2000	○	○	○			
MC-30	3000	○	○	○			
MC-40	4000	○	○	○			
MC-50	5000			○	○	○	○
MC-60	6000			○	○	○	

Standard Specifications

Power source	AC100V
Power consumption	Single-phase, 100 VAC, 1A max.
Conveyance speed at 50Hz	5.4 m/min.
60Hz	6.5 m/min.
Payload	25 kg
Conveyor height (from floor to belt surface)	1000~1600 mm (For the MC50 and larger models, 1000 to 1500 mm in steps of 50 mm)
Conveyer length	2000, 3000, 4000, 5000, 6000 (mm)
Belt width	300, 400, 500, 600, 700, 1000 (mm)
Frame width	Belt width plus 80 mm
Total width	Belt width plus 142 mm

Main accessories

Special leg (special height)	Semi-standard	Rough-surface belt	Semi-standard
Stacked pallets counter		Take-out robot descent inhibit sensor	Semi-standard
Variable speed motor		Fast forward switch	Semi-standard
Heat-resisting belt		Knife edge	Semi-standard
Side guide	Semi-standard	Emergency stop switch	Semi-standard
Upper-surface guide	Semi-standard	Weight resisting leg	Semi-standard
Belt with crosspieces	Semi-standard	Level pad*	Semi-standard
Defective product-release circuit	Semi-standard	Caster**	
Overload warning device			
Anti-electrostatic device	Semi-standard	Harness extension for linking with take-out robot***	Semi-standard

Semi-standard: This is a semi-standard accessory, which requires additional time for manufacturing.
* Available as standard for the MC-50 and larger models.
** Optionally available for the MC-50 and larger models.
*** 8 m (Standard) → 16 m

Dimensions (mm)

MC-20/30/40

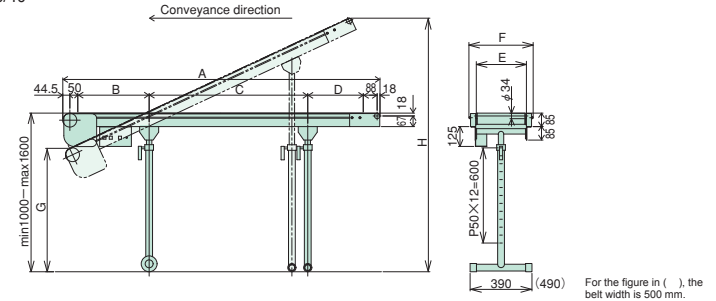

Model	A	B	C	D	E	F	G	H
MC-20-3					300	442		
-4	2000	450	1000	350	400	542	790	1565
-5					500	642		
MC-30-3					300	442		
-4	3000	600	1400	800	400	542	735	1889
-5					500	642		
MC-40-3					300	442		
-4	4000	600	2400	800	400	542	834	1818
-5					500	642		

Dimensions (mm)

MC-50/60

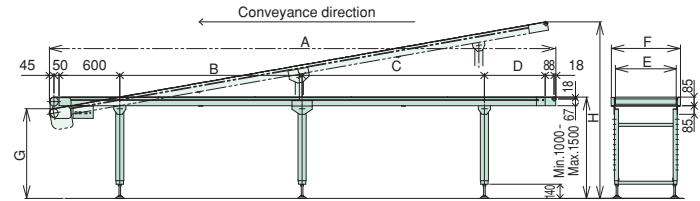

Model	A	B	C	D	E	F	G	H
MC-50-5					500	642		
-6	5000	1800	1800	600	600	742	884	1755
-7					700	842		
-10					1000	1142		
MC-60-5					500	642		
-6	6000	2300	2300	600	600	742	910	1720
-7					700	842		